

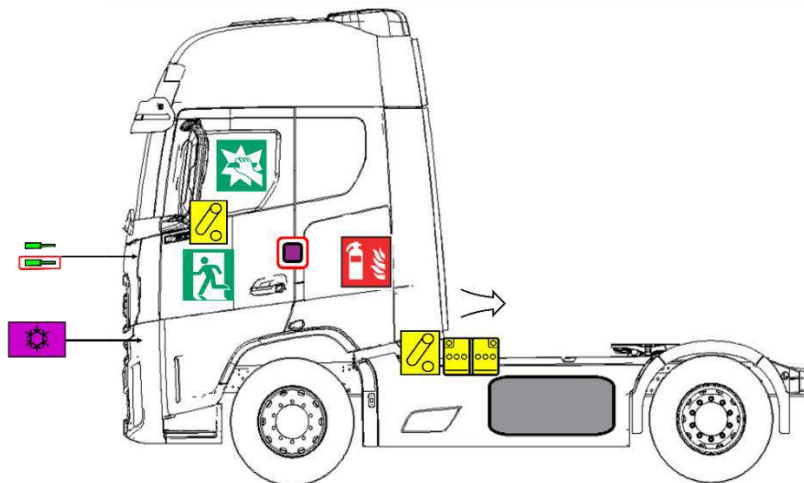

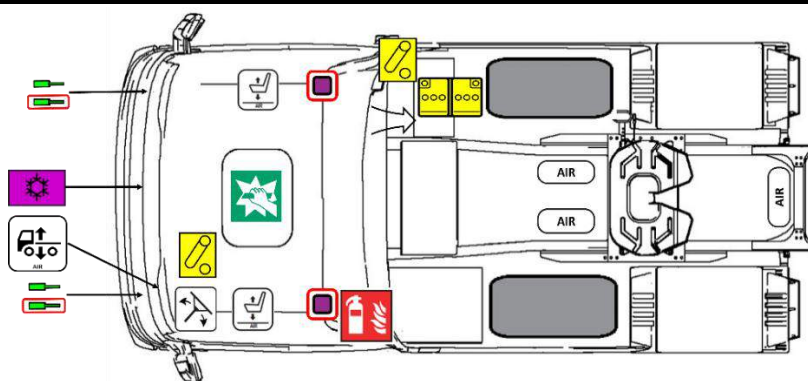







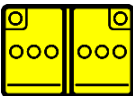





FORD LASTEBILER

4x2 F-MAX Diesel

Produksjonsstart: 2025



 Lav batterispenning	 Lufttank	 Ratt, vippekontroll	 Setehøydejustering med luftsystem	 Luftinntak	 Sikkerhetsbelte pretensjoner	 Gassfjærbein / Forspent fjær
 Enhet for å slå av strømmen i kjøretøyet	 Innhold i drivstofftanken Diesel	 Komponent for luftkondisjonering	 Brudd for å få tilgang	 Nødutgang	 Brannslukningsapparat	 Truck med høyderegulering, etter luftsystem
FORD 4x2 F-MAX Diesel			Identifikasjonsnummer	Versjonsnummer	Sidenummer	
			FO_2025_625_001	01	1/4	

1. Identifisering/gjenkjenning



2. Immobilisering / stabilisering / løfting



3. Deaktiver direkte farer / Sikkerhetsforskrifter



For lastebiler med startnøkkel

(1): Slå om mulig av startbryteren og ta ut nøkkelen.

For lastebiler med start/stopp-knapp Trykk kort på knappen.

For lastebiler med ADR: Trykk på batterihovedbryteren (2). Vri batteriets hovedbryter (3) eller (4) til OFF-stilling.

Merk: For lastebiler med ADR er hovedbryteren en fysisk strømbryter. Hovedbryteren åpner ADR-reléene for å koble fra 12 V-batteriene.



Plasseringen av batterikassen er den samme i F-MAX-kjøretøyene. Plasseringen endres ikke. Bildene viser standardplasseringen (A). Batteriets hovedbryter skal brukes til å slå av spenningen i kjøretøyet.

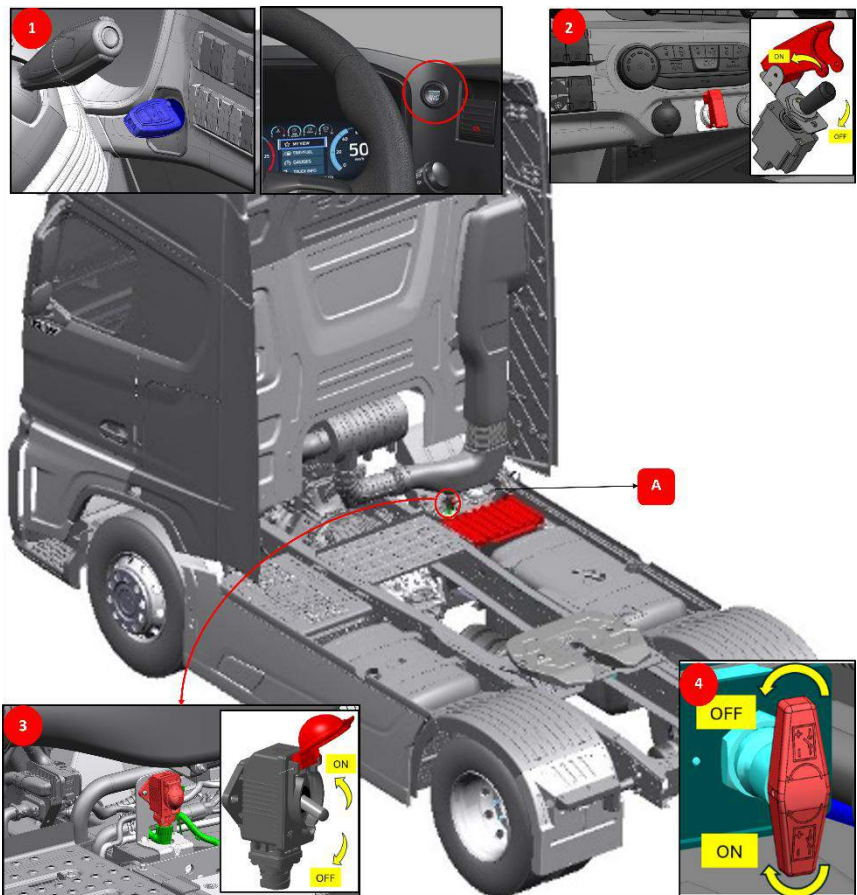

FORD 4x2 F-MAX Diesel

Identifikasjonsnummer

FO_2025_625_001

Versjonsnummer

01

Sidenummer

2/4

4. Toegang voor passagiers







1. Gjennom fører- eller passasjerdør
2. Bryt gjennom sidevinduet

A : Laminert glass

B: Herdet glass



5. Lagret energi / væsker/ gasser/ faste stoffer

		12V + 12V
		600 L + 250 L
		730 g
		85 L

6. I tilfelle brann



7. I tilfelle nedsenking



FORD 4x2 F-MAX Diesel

Identifikasjonsnummer

FO_2025_625_001

Versjonsnummer

01

Sidenummer

3/4

8. Tauing/ transport/ lagring

1. Festepunktet for slepeøyet er plassert under støtfangeren foran



2. Slå av strømmen til kjøretøyet (se avsnitt 3. Deaktivering av direkte farer/sikkerhetsforskrifter).

3. Hold deg unna brennbare og eksplosive materialer.

Tillatte metoder:

1. Tauing. **(Merk: Bruk kun fremre slepeøye for å taue bilen med alle hjulene på bakken).**

2. Drivverket til hjulene deaktiveres enten ved å koble propellakselen (1) fra drivakselen (2) eller ved å fjerne drivakslene (3).

3. Transport av

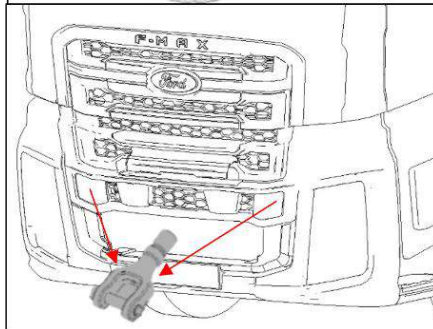
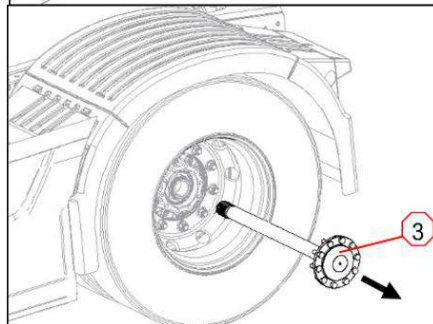
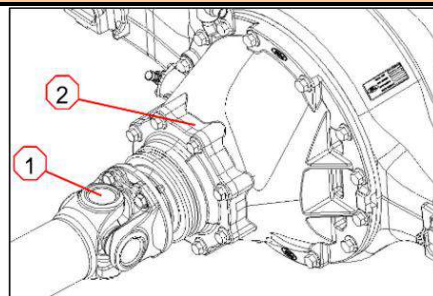

9. Viktig tilleggsinformasjon



Ikke utfør arbeid på en skadet lastebil uten egnet personlig verneutstyr (PPE).

Se førerhåndboken eller håndboken for redning og tauing for mer detaljert informasjon.

10. Forklaring Piktogrammer som brukes

	Farlig for menneskers helse		Irriterende stoffer
	Etsende stoffer		Gasser under trykk
	Eksplosiv		Bruk ABC-pulver til å slukke brannen
	Miljøfare		Advarsel, Elektrisitet
	Brannfarlig		Generelt advarselsskilt
FORD 4x2 F-MAX Diesel		Identifikasjonsnummer	Versjonsnummer
		FO_2025_625_001	01
			Sidenummer
			4/4